

# Fastair



**ALPHA**  $\alpha$  **POMPE** s.p.a.



**Serie FA**

Valvole Pneumatiche Coassiali



**FA Series**

Pneumatic Coaxial Valves



**FA Series**

Koaxial Pneumatikventile



**Série FA**

Vannes Pneumatiques Coaxiaux

**2016**

PAT. PENDING  
N. MI2011A-2087

# FAST-AIR

## VALVOLE PNEUMATICHE COASSIALI - PNEUMATIC COAXIAL VALVES KOAXIAL PNEUMATIKVENTILE - VANNES PNEUMATIQUES COAXIAUX

### UNIDIREZIONALE

Valvola pneumatica coassiale tipo ON-OFF,  
dispositivo di azionamento pneumatico incorporato, funzione DA o SR



#### CARATTERISTICHE GENERALI

**CORPO:** Alluminio estruso EN AW 6063, anodizzato duro 50 um.  
**PISTONE:** Alluminio estruso EN AW 6063, anodizzato duro 50 um.  
**COPERCHI:** Alluminio EN AB 46400, anodizzato 30 um.  
**DIAFRAMMA:** Acciaio INOX AISI 316.  
**GUARNIZIONI:** NBR, EPDM, FPM/FKM, Silicone.  
**MOLLA:** Acciaio INOX AISI 302.  
**FLUIDO:** Gruppo 2 – NON PERICOLOSI.  
**TEMPERATURE DI LAVORO:** -40 +150°C.  
**PRESSIONE DI LAVORO:** MAX 16 BAR (PN 16).  
**TENUTA A VUOTO:** 740 mmHg (97,4%).  
**TAGLIE:** DN 10 - 15 - 20 - 25 - 32 - 40 - 50 PASSAGGIO TOTALE.  
**FILETTATURA VALVOLA:** GAS UNI 228-1.

**FLUIDO DI COMANDO:** aria compressa secca o lubrificata,  
Filtrata 30 um (ISO 5873 Part 1, Class 5).  
**ATTACCHI FLUIDO DI COMANDO:** 1/8" GAS (optional NPT).  
Attacco NAMUR per elettrovalvole 1/4".  
**PRESSIONE DI COMANDO:**  
DA (doppio effetto) = 3 - 8 BAR  
SR (semplice effetto) = 4,2 - 8 BAR

**OPTIONAL:** - Nickelatura chimica (AF 12%) 20 um.  
- Rivestimento PTFE 20 um.  
- Anello magnetico per micro-proximity.

Funzionamento indipendente dalla pressione del fluido interno.  
Facile montaggio in qualsiasi posizione, nessuna parte mobile esterna.  
Doppie tenute sul fluido per lunga durata. Basso consumo di aria.  
Sede tipo "B" (6,5x3,5 mm) sul corpo per micro proximity.

PED-2014/68/UE, Art. 4.3. MD-2006/42/CE, All.to II.1.B.

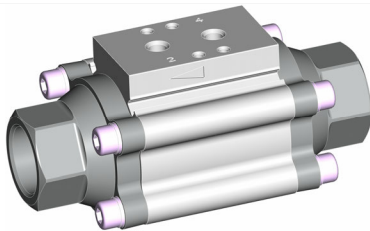

### UNIDIREKTIONAL

Auf-zu Koaxialventil, mit integriertem pneumatischen Antrieb,  
DA doppelt oder SR einfachwirkend



#### ALLGEMEINE EIGENSCHAFTEN

**KÖRPER:** Extrudiertes Aluminium EN AW 6063, hartanodisiert 50 um.  
**DECKEL:** Extrudiertes Aluminium EN AW 6063, hartanodisiert 50 um.  
**KOLBEN:** Aluminium EN AB 46400, anodisiert 30 um.  
**DIAPHRAGMA:** Edelstahl AISI 316.  
**DICHTUNGSMATERIALIEN:** NBR, EPDM, FPM/FKM, Silicone.  
**FEDER:** ROSTFREIER Stahl AISI 302.  
**FLÜSSIGKEITSTYP:** Gruppe 2 - kein Gefahrgut.  
**TEMPERATURBEREICH:** -40 +150°C.  
**DRUCKSTUFE - PN 10:** MAX 16 BAR (PN 16).  
**VAKUUM DICHTHEIT:** 740 mmHg (97,4%).  
**GRÖSSEN:** DN 10 - 15 - 20 - 25 - 32 - 40 - 50 VOLLER DURCHGANG.  
**ANSCHLUSSGEWINDE:** GAS UNI 228-1.

**BETÄTIGUNG:** Trockene oder geschmierte Druckluft,  
gefiltriert, 30 um (ISO 5873 Teil 1, Class 5).  
**Steuerluftanschluss:** G1/8", optional NPT Gewinde.  
NAMUR Anschluss für 1/4" Vorsteuerventile.  
**STEUERLUFTDRUCK:**  
DA (doppeltwirkend) = 3-8 bar  
SR (einfachwirkend) = 4,2-8 bar

**OPTIONAL:** - Chemisch Vernickelt (Phosphorgehalt 12%) 20 um.  
- PTFE- Beschichtung 20 um.  
- Magnetring für Näherungssensor.

Die Funktion ist unabhängig von dem Mediendruck.  
Montage in jeder Position, keine äusseren bewegten Teile.  
Doppelte Dichtung für lange Lebensdauer am Fluid. Geringer Luftverbrauch.  
Typ B Sitz für Näherungsschalter (6,5x3,5 mm).

PED-2014/68/UE, Art. 4.3. MD-2006/42/CE, Anh. II.1.B.

### UNIDIRECTIONAL

ON-OFF pneumatic coaxial valve, with  
internal pneumatic actuator device, DA or SR operation



#### GENERAL FEATURES

**BODY:** EN AW 6063 Extruded Aluminium, 50 um hard anodized.  
**PISTON:** EN AW 6063 Extruded Aluminium, 50 um hard anodized.  
**COVERS:** EN AB 46400 Aluminium, 30 um anodized.  
**DIAPHRAGM:** AISI 316 Stainless Steel.  
**GASKETS:** NBR, EPDM, FPM/FKM, Silicone.  
**SPRING:** AISI 302 Stainless Steel.  
**FLUID:** Group 2 – NON DANGEROUS.  
**WORKING TEMPERATURE:** -40 +150°C  
**WORKING PRESSURE:** MAX 16 BAR (PN 16)  
**VACUUM SEALING:** 740 mmHg (97,4%)  
**SIZES:** DN 10 - 15 - 20 - 25 - 32 - 40 - 50 TOTAL PASSAGE  
**VALVE THREAD:** GAS UNI 228-1

**PILOT FLUID:** dry or lubricated compressed air,  
30 um filtered (ISO 5873 Part 1, Class 5).  
**PILOT FLUID PORTS:** 1/8" GAS (optional NPT).  
NAMUR connection for 1/4" solenoid valves.  
**PILOT PRESSURE:**  
DA (double acting) = 3 - 8 BAR  
SR (spring return) = 4,2 - 8 BAR

**OPTIONAL:** - 20 um nickel-plating (HP 12%).  
- 20 um PTFE coating.  
- Magnetic ring for proximity micro-switch.

Operation is independent from internal fluid pressure.  
Easy assembly in any position, no external moving part.  
Double sealing on fluid for long duration. Low air consumption.  
Type "B" seat (6,5x3,5 mm) on body for proximity micro-switch.

PED-2014/68/UE, Sec. 4.3. MD-2006/42/CE, Annex II.1.B.

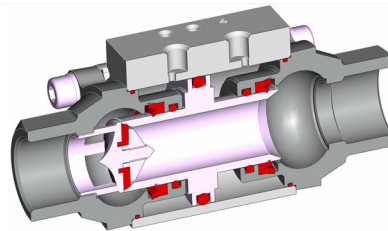

### UNIDIRECTIONELLE

Vanne pneumatique coaxiale ON-OFF,  
avec contrôle pneumatique intégré, fonction DA ou SR



#### CARACTÉRISTIQUES GÉNÉRALES

**CORPS:** Aluminium extrudé EN AW 6063, à haute anodisation 50 um.  
**PISTON:** Aluminium extrudé EN AW 6063, à haute anodisation 50 um.  
**COUVERCLES:** Aluminium EN AB 46400, anodisé 30 um.  
**DIAPHRAGME:** Acier INOXYDABLE AISI 316.  
**JOINTS:** NBR, EPDM, FPM/FKM, Silicone.  
**RESSORT:** Acier INOXYDABLE AISI 302.  
**FLUIDE:** Groupe 2 – NON DANGEREUX.  
**TEMPÉRATURE DE TRAVAIL:** -40 +150°C.  
**PRESSION DE TRAVAIL - PN 10:** MAX 16 BAR (PN 16).  
**ÉTANCHEITÉE SOUS VIDE:** 740 mmHg (97,4%).  
**TAILLES:** DN 10 - 15 - 20 - 25 - 32 - 40 - 50 PASSAGE TOTAL.  
**FILETAGE VANNE:** GAS UNI 228-1.

**FLUIDE DE CÔNTRÔLE:** air comprimé sec ou lubrifié,  
Filtré 30 um (ISO 5873 Part 1, Class 5).  
**FILETAGE FLUIDE DE CÔNTRÔLE:** 1/8" GAS.  
Connexion NAMUR pour electrodistributeurs 1/4".  
**PRESSION DE CÔNTRÔLE:**  
DA (double effet) = 3 - 8 BAR  
SR (simple effet) = 4,2 - 8 BAR

**OPTIONNEL:** - Nickel chimique (HP 12%) 20 um.  
- 20 um placage PTFE.  
- Aneau magnetique pour micro proximité.

Fonctionnement indépendant de la pression du fluide à l'intérieur.  
Installation facile dans toute position, sans pièces mobiles à l'extérieur.  
Double joint sur le fluide pour longue durée. Consommation d'air réduite.  
Siège type "B" (6,5x3,5 mm) sur le corps pour micro proximité.

PED-2014/68/UE, Art. 4.3. MD-2006/42/CE, Annexe II.1.B.

FUNZIONAMENTO PNEUMATICO – PNEUMATIC OPERATION  
 PNEUMATISCHE FUNKTION – FONCTIONNEMENT PNEUMATIQUE

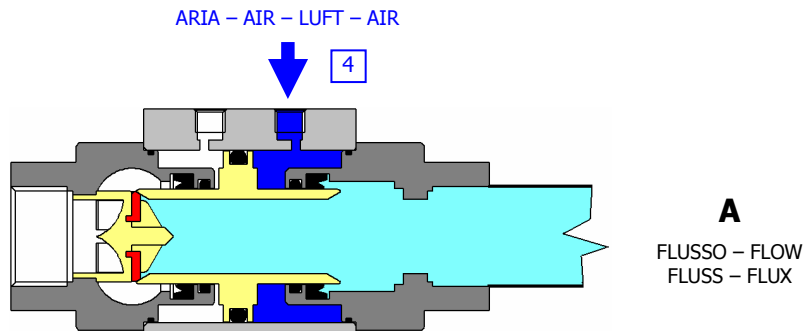

CHIUSURA DELLA VALVOLA

VALVE CLOSING

Pressione di comando alla porta "4"

Pilot pressure supply to "4" port

L'aria di alimentazione spinge il pistone contro la guarnizione piana del diaframma, ed arresta il flusso del fluido.  
 Disponibile anche la versione "SR" con molle di ritorno (NO/NC).

Feeding air pushes the piston against the flat gasket of the diaphragm, and stops flow passage.  
 Spring Return "SR" version also available (NO/NC).

Steuerluft an Anschluss "4"

Pression de contrôle à la porte "4"

Die Steuerluft schiebt den Kolben gegen die Flachdichtung des Diaphragmas und verschließt somit den Durchfluss.  
 Federkraft Betätigung NC und NO ist auch erhältlich.

L'air d'alimentation pousse le piston contre le joint plat du diaphragme, et bloque le flux du fluide.  
 Aussi disponible la version "SR" avec avec ressorts de retour (NO/NC).

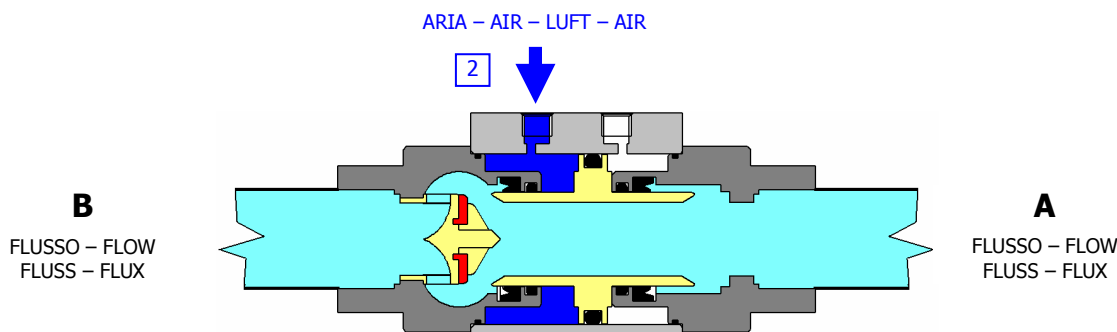

APERTURA DELLA VALVOLA

VALVE OPENING

Alimentazione della pressione di comando alla porta "2"

Pilot pressure supply to "2" port

L'aria di alimentazione allontana il pistone dalla guarnizione piana del diaframma, e permette il flusso del fluido.  
 Disponibile anche in versione "SR" con molle di ritorno (NO/NC).

Feeding air takes the piston away from the diaphragm, and allows flow passage.  
 Spring Return "SR" version also available (NO/NC).

Steuerluft an Anschluss "2":

Pression de contrôle à la porte "2"

Die Steuerluft schiebt den Kolben vom Diaphragma weg und öffnet so den Durchgang.  
 Federkraft Betätigung NC und NO ist auch erhältlich.

L'air d'alimentation éloigne le piston du joint plat du diaphragme, et permet le flux du fluide.  
 Aussi disponible la version "SR" avec avec ressorts de retour (NO/NC).

SCHEMA PNEUMATICO – PNEUMATIC SCHEME  
 PNEUMATIK SCHALTSCHEMATA – SCHÉMA PNEUMATIQUE

<p>Versione "DA"                  "DA" Version                  Version "DA"                  Version "DA"</p>	<p>Versione "SR" (NC) <b>Norm. CHIUSA</b>                  "SR" (NC) Version <b>Normally CLOSE</b>                  Version "SR" (NC) <b>Norm. GESCHLOSSEN</b>                  Version "SR" (NC) <b>Norm. FERMÉE</b></p>	<p>Versione "SR" (NO) <b>Norm. APERTA</b>                  "SR" (NO) Version <b>Normally OPEN</b>                  Version "SR" (NO) <b>Norm. GEÖFFNET</b>                  Version "SR" (NO) <b>Norm. OUVERTE</b></p>

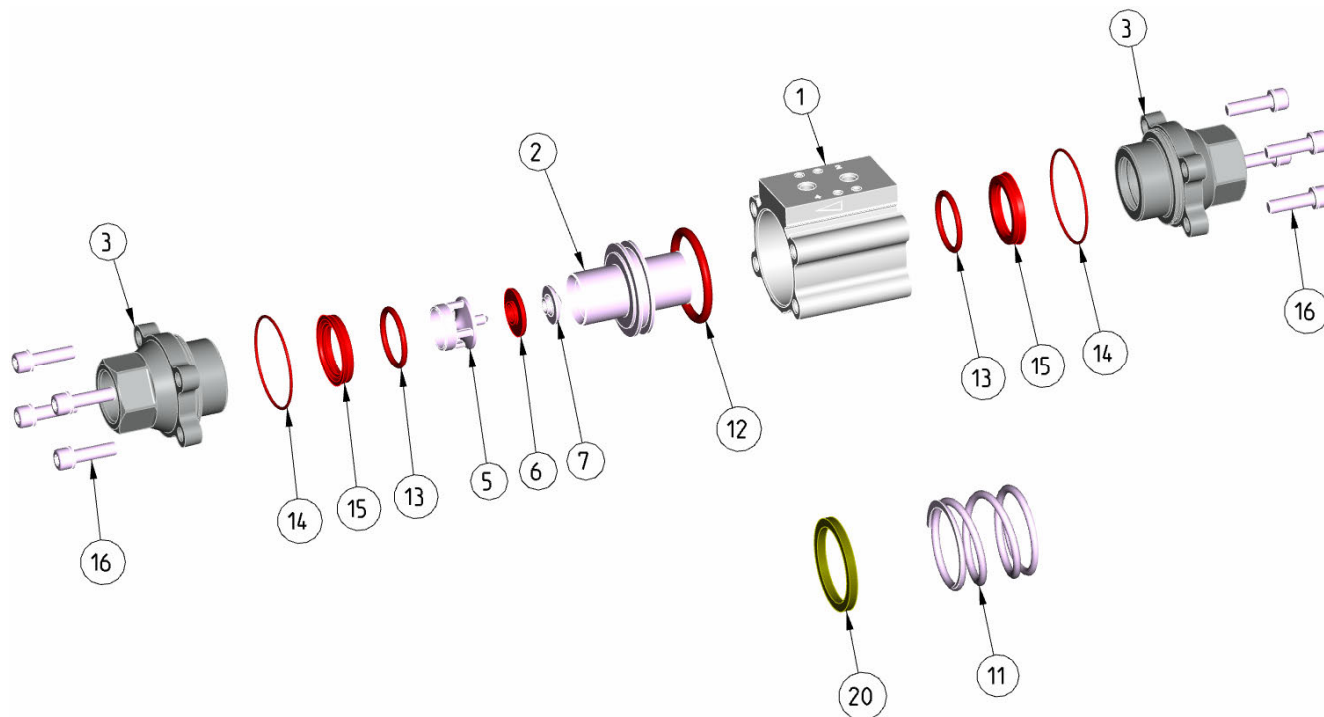

PARTE PART TEIL PARTIE	Qt.	DESCRIZIONE DESCRIPTION BESCHREIBUNG DESCRIPTION	MATERIALI MATERIALS MATERIALEN MATÉRIAUX	TRATTAMENTI COATINGS BESCHICHTUNGEN REVÊTEMENTS
<b>1</b>	1	Corpo, Body, Körper, Corps	EN AW 6063 Aluminium	A - N - TF
<b>2</b>	1	Pistone, Piston/shuttle, Kolben, Piston	EN AW 6063 Aluminium	A
<b>3</b>	2	Coperchi, Covers, Deckel, Couvercles	EN AB 46400 Aluminium	A - N - TF
<b>5</b>	1	Diaframma, Diaphragm, Diaphragma, Diaphragme	AISI 316 (A4) Stainless Steel	
<b>* 6</b>	1	Guarnizione piana, Flat gasket, Flachdichtung, Joint plat	NBR, EPDM, FPM/FKM, Silicone	
<b>7</b>	1	Ghiera, Nut ring, Sicherungsring, Ferrule	AISI 316 (A4) Stainless Steel	
<b>11</b>	1	Molla, Spring, Feder, Réssort (SRNO-SRNC)	AISI 302 Stainless Steel	
<b>* 12</b>	1	O-RING (pistone, piston, kolben, piston)	NBR, EPDM, FPM/FKM, Silicone	
<b>* 13</b>	2	O-RING (interno, internal, innen, interne)	NBR, EPDM, FPM/FKM, Silicone	
<b>* 14</b>	2	O-RING (coperchio, cover, deckel , couvercle)	NBR, EPDM, FPM/FKM, Silicone	
<b>* 15</b>	2	Guarnizione a labbro, Lip seal, Lippendichtung, Joint à lèvres	NBR, EPDM, FPM/FKM, Silicone	
<b>16</b>	8	Vite , Screw, Schraube, Vis	AISI 304 (A2) Stainless Steel	
<b>20</b>	1	Anello magnetico per micro proximity Magnetic ring for proximity microswitch Magnetring für Näherungsschalter Anneau magnétique pour micro-interrupteur de proximité	Ferrite	(OPTIONAL) -20 +80°C

\* SET RICAMBI - SPARE-PARTS SET - ERSATZTEILSET- PIÈCES DÉTACHÉES

#### TRATTAMENTI SUPERFICIALI

**A** = Ossidazione Anodica DURA 50 um  
**N** = Nickelatura Chimica ALTO FOSFORO (12%) 20 um  
**TF** = Ossidazione Anodica DURA 50 um + PTFE 20 um

#### EXTERNAL COATINGS

**A** = 50 um HARD Anodizing  
**N** = 20 um HIGH PHOSPHOROUS (12%) Chemical Nickel Plating  
**TF** = 50 um HARD Anodizing + 20 um PTFE coating

#### OBERFLÄCHENBEHANDLUNG

**A** = Harteloxiert 50 um  
**N** = 20 um Chemisch Vernickelt mit hohem Phosphorgehalt (12%)  
**TF** = 50 um Harteloxiert mit 20 um PTFE Beschichtung

#### REVÊTEMENTS DES SURFACES

**A** = 50 um Protection à HAUTE Anodisation  
**N** = 20 um Nickel Chimique TENEUR ÉLEVÉE EN PHOSPHORE (12%)  
**TF** = 50 um Protection à HAUTE Anodisation + 20 um placage PTFE

**PESI E DIMENSIONI – WEIGHT AND DIMENSIONS  
ABMESSUNGEN UND GEWICHTE – POIDS ET DIMENSIONS**

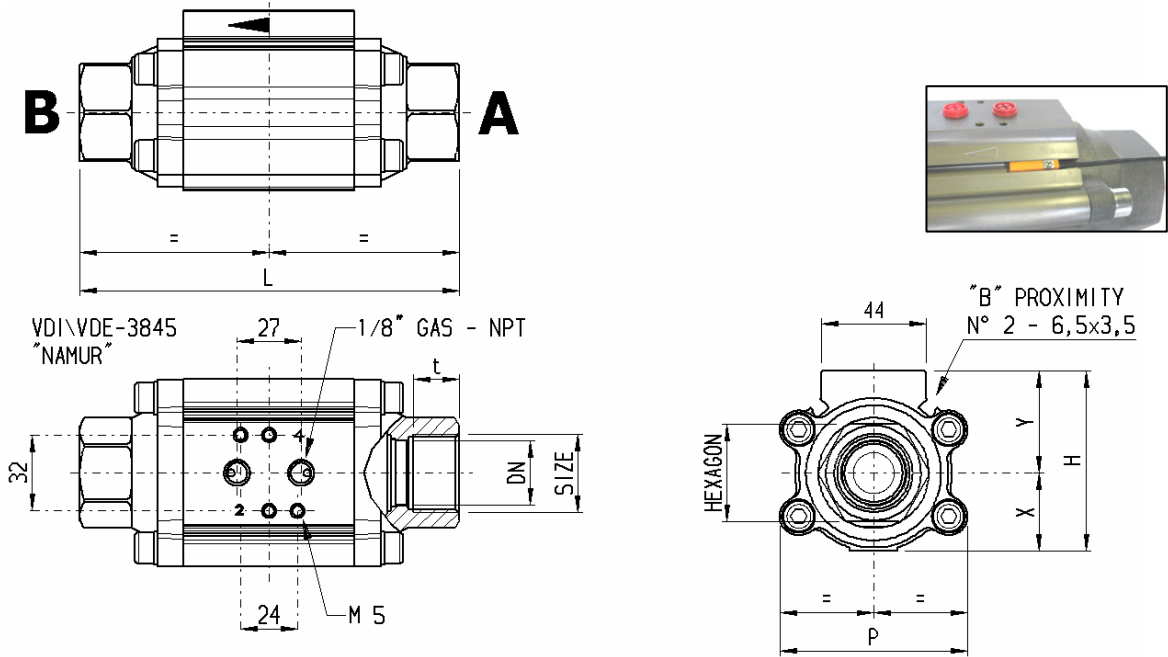

VALVOLA VALVE VENTIL VANNE	DN	TAGLIA SIZE GRÖSSE TAILLE	VOLUME VOLUME VOLUMEN VOLUME	t	L	P	H	x	y	Esagono Hexagon Sechskant Hexagone	Peso DA DA Weight DA Gewicht DA Poids	Peso SR SR Weight SR Gewicht SR Poids
FA 10	DN 10	3/8"	\	\	\	\	\	\	\	\	\	\
FA 15	DN 15	1/2"	Lt. 0,080	15	128	58	57	23	34	30	Kg. 0,570	Kg. 0,600
FA 20	DN 20	3/4"	Lt. 0,145	16.3	146	68	69	29	40	33	Kg. 0,750	Kg. 0,810
FA 25	DN 25	1"	Lt. 0,210	19.1	160	79	76	33	43	41	Kg. 1,000	Kg. 1,100
FA 32	DN 32	1" 1/4	Lt. 0,381	21,4	188	89	88	39	49	50	Kg. 1,500	Kg. 1,680
FA 40	DN 40	1" 1/2	Lt. 0,541	21,4	206	106	98	44	54	60	Kg. 2,200	Kg. 2,420
FA 50	DN 50	2"	Lt. 0,850	25.7	232	117	111	51	60	75	Kg. 2,880	Kg. 3,230

**PERDITE DI CARICO  $\Delta p$  IN BAR –  $\Delta p$  PRESSURE DROP IN BAR  
 $\Delta p$  DRUCKABFALL IN BAR – CHUTE DE PRESSION  $\Delta p$  EN BAR**

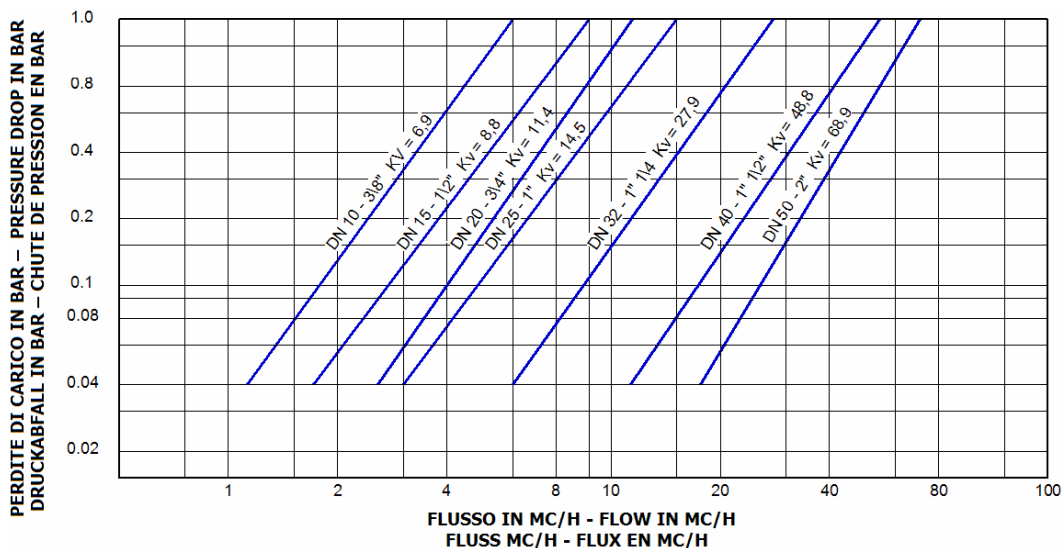

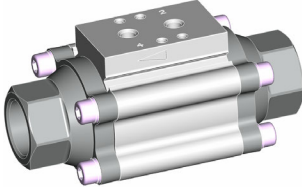
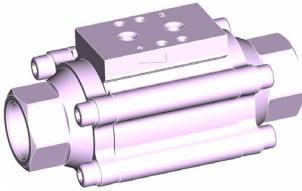
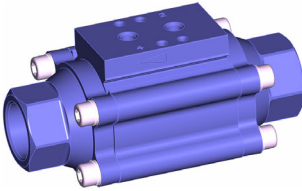

**TRATTAMENTI SUPERFICIALI – EXTERNAL COATINGS  
OBERFLÄCHENBEHANDLUNG – REVÊTEMENTS DES SURFACES**

		COMPONENTE – PART – TEIL – PARTIE			
		Corpo, Body Körper, Corps	Coperchi, Covers Deckel, Couvertcles	Pistone, Piston Kolben, Piston	
	<b>A</b>  standard	Ossidazione Anod.Dura	Ossidazione Anod.Dura	Ossidazione Anod.Dura	Industria, uso generale Industry, General use Industrie, allgemeine Anwendungen
		Hard Anodizing	Hard Anodizing	Hard Anodizing	
		Hartanodisiert	Hartanodisiert	Hartanodisiert	
		Haute Anodisation	Haute Anodisation	Haute Anodisation	
	Colore, Colour Farbe, Couleur	Grigio scuro, Dark grey Dunkelgrau, Gris foncé	Grigio scuro, Dark grey Dunkelgrau, Gris foncé	Grigio scuro, Dark grey Dunkelgrau, Gris foncé	Industrie, utilisation générale
Spessore, Thickness Dicke, Épaisseur	50 µ	30 µ	50 µ		
	<b>N</b>	Ossidazione Anod.Dura	Ossidazione Anod.Dura	Ossidazione Anod.Dura	Industria, uso generale Soda caustica, detersivi Soluzioni debolmente alcaline Industry, General use Caustic soda, detergents Low alkaline solutions Industrie, allgemeine Anwendungen, Natronlauge, Reinigungsmittel schwach alkalischen Lösungen
		Nickel Chimico Alto Fosforo	Nickel Chimico Alto Fosforo		
		High phosphorous nickel-plating	High phosphorous nickel-plating	High phosphorous nickel-plating	
		Chemisch vernickelt mit hohem Phosphorgehalt	Chemisch vernickelt mit hohem Phosphorgehalt	Chemisch vernickelt mit hohem Phosphorgehalt	
	Colore, Colour Farbe, Couleur	Acciaio, Steel Stahl, Acier	Acciaio, Steel Stahl, Acier	Grigio scuro, Dark grey Dunkelgrau, Gris foncé	Industrie, utilisation générale Soude caustique, détergents Solutions faiblement alcalines
Spessore, Thickness Dicke, Épaisseur	20 µ	20 µ	50 µ		
	<b>TF</b>	Ossidazione Anodica Dura + rivestimento PTFE	Ossidazione Anodica Dura + rivestimento PTFE	Ossidazione Anodica Dura	Industria, uso generale Soluzioni debolmente alcaline e debolmente acide Ambiente marino Alte temperature Industry, general use Low alkaline and low acid solutions Marine environments High temperatures Industrie, allgemeine Anwendungen, Schwach alkalische und schwach saure Lösungen Marine-Umgebungen Hohe Temperaturen
		Hard Anodizing + PTFE coating	Hard Anodizing + PTFE coating	Hard Anodizing	
		Hartanodisiert + PTFE Überzug	Hartanodisiert + PTFE Überzug	Hartanodisiert	
		Haute Anodisation + placage PTFE	Haute Anodisation + placage PTFE	Haute Anodisation	
	Colore, Colour Farbe, Couleur	Blu, Blue Blau, Bleu	Blu, Blue Blau, Bleu	Grigio scuro, Dark grey Dunkelgrau, Gris foncé	Industrie, utilisation générale Solutions faiblement alcalines et faiblement acides environnement marin températures élevées
Spessore, Thickness Dicke, Épaisseur	Hard Anod. 50 µ + PTFE 20 µ	Hard Anod. 50 µ PTFE 20 µ	50 µ		

**CARATTERISTICHE TECNICHE**

**OSSIDAZIONE ANODICA DURA:** Trattamento elettrolitico che produce uno strato di ossido (ALLUMINA), con spessore standard 50 µm. L'allumina è uno dei materiali più duri che si conoscano, durezza superficiale 400-600 HV (45-65 HRC). Le proprietà meccaniche e la resistenza chimica sono molto apprezzate.

**NICKELATURA CHIMICA:** Processo chimico senza elettricità di deposito di nickel e fosforo (max 12%) con spessori uniformi 20 µm anche su spigoli, fori ciechi, filetti e canali. Durezza superficiale 400-480 HV (45-55 HRC).

**OSSIDAZIONE ANODICA DURA + PTFE:** E' un ulteriore miglioramento dell'ossidazione anodica, con rivestimento 20 µm a base di PTFE. Si sommano la durezza dell'ossido (per parti interne soggette a usura) con la eccezionale resistenza chimica e termica del PTFE (per parti esterne soggette a corrosione).

**TECHNISCHE DETAILS**

**Hartanodisiert:** versteht man die elektrolytische Oxidation von Aluminiumwerkstoffen, um Schutzschichten auf zu erzeugen. Die Schicht hat eine Härte von 400-600 HV (45-65 HRC) und dient als Verschleiß- und Korrosionsschutz, ist thermisch und elektrisch isolierend und hat gute Eigenschaften.

**Chemische Vernickeln:** Chemisches Verfahren ohne Anlegen elektrischer Spannung. Nickel und Phosphor bilden eine gleichmäßige Schichtdicke (20 µm), auch an Ecken, Sacklöcher, Gewinde und Kanälen. Die Oberflächenhärte liegt bei 400-480 HV (45-55 HRC).

**Anodisierung und einer PTFE Überzug:** verbindet die Vorteile der harten Oberfläche mit den chemischen und physikalischen Vorteilen des PTFE. Die Härte der Anodisierung (exzellent für die Innenteile, unterliegen einem Verschleiß) mit der hervorragenden chemischen und thermischen Beständigkeit von PTFE (für externe Teile, die einer Korrosion) aufgenommen.

**TECHNICAL FEATURES**

**HARD ANODIZING:** Electrolytic process that produces an anodic layer on aluminum (ALUMINE), with 50 µm thickness. Alumine is one of the hardest known materials, surface hardness 400-600 HV (45-65 HRC). Its mechanical properties and chemical resistance are well appreciated.

**ELECTROLESS NICKEL-PLATING:** Electroless chemical process gives a nickel and phosphor (max 12%) layer. 20 µm constant thickness also on shapes, blind-holes, threads and recesses. Surface hardness 400-480 HV (45-55 HRC).

**HARD ANODIZING + PTFE COATING:** It is a further improvement of hard anodizing, with a 20 µm coating made of PTFE. Oxide hardness (for internal parts subject to wear), and excellent chemical/thermal resistance of PTFE (for external surfaces subject to corrosion) are summed.

**CARACTÉRISTIQUES TECHNIQUES**

**HAUTE ANODISATION.** Traitement électrolytique qui produit une couche d'oxyde (ALUMINE), avec épaisseur standard de 50 µm. L'alumine est l'un des matériaux les plus durs connus, 400-600 HV (45-65 HRC). Ses propriétés mécaniques et sa résistance chimique sont très appréciés.

**NICKEL CHIMIQUE.** Procédé chimique sans d'électricité de dépôt du nickel et de phosphore (max 12%) avec une épaisseur uniforme de 20 µm, même dans coins, trous borgnes, fils et canaux. Dureté de surface 400-480 HV (45-55 HRC).

**HAUTE ANODISATION + PTFE.** C'est une amélioration supplémentaire de l'haute anodisation, obtenue par 20 µm revêtement à base de PTFE. La dureté de l'anodisation (pour parties internes soumises à l'usure) s'ajoute à une exceptionnelle résistance chimique et thermique du PTFE (pour parties extérieures soumises à corrosion).

COMPANY WITH  
QUALITY SYSTEM  
CERTIFIED BY DNV GL  
= ISO 9001 =



EN UNI 10204  
**3.1**





**CONDIZIONI GENERALI DI VENDITA**

**ORDINI.** Gli ordini trasmessi ai nostri Agenti sono validi solo se convalidati dalla nostra Direzione commerciale.

**PREZZI.** I prezzi si intendono senza oneri fiscali. I prezzi possono essere modificati, senza preavviso, in conseguenza dell'andamento generale dei costi o per altre cause. I prezzi di listino sono relativi alle costruzioni normali di serie.

**CONSEGNE.** Ritardi dovuti a cause di forza maggiore o altro, non giustificano l'annullamento dell'ordine, né alcuna indennità potrà essere richiesta. Si ritengono autorizzate anche consegne parziali, fatte cioè in diverse riprese. Imballo eventuale a costo.

**SPEDIZIONI.** Il materiale viaggia a rischio e pericolo del committente. Il committente, in caso di contestazioni, deve immediatamente segnalare il fatto al trasportatore con lettera raccomandata e copia a noi.

**PAGAMENTI.** Le nostre fatture sono pagabili per contanti o secondo le modalità stabilite e accettate in sede di ordinazione. Per ordini di materiale speciale vale la regola:  
- un terzo del pagamento all'ordine;  
- il saldo a trenta giorni fine mese dalla data di spedizione.

**PROPRIETA' DEL MATERIALE.** Il nostro diritto di proprietà sul materiale consegnato è valido fino al pagamento totale della fattura corrispondente. Un ritardo ingiustificato nel pagamento concordato ci dà diritto di esigere la restituzione immediata, porto franco, del materiale consegnato.

**GARANZIA.** La garanzia generale dura 6 mesi, a partire dalla data di spedizione del materiale. Naturalmente la garanzia copre ogni difetto di costituzione del materiale che noi stessi fabbrichiamo. La nostra garanzia si limita alla sostituzione o alla riparazione, presso la nostra officina e a nostra cura, dell'attuatore o del pezzo riconosciuti come difettosi. In nessun caso, comunque, la garanzia implica la possibilità di richiesta di indennità. Sono escluse dalla garanzia le avarie provocate da errori di collegamento, da mancanza di protezione adeguata, da montaggio difettoso, da false manovre e comunque da mancanza di cura nell'esecuzione dell'impianto. La garanzia non può essere riconosciuta inoltre nei casi che seguono: - mancato buon funzionamento provocato da installazioni non eseguite a perfetta regola d'arte; - nei casi in cui il cliente non è in regola con i pagamenti; - è escluso dalla nostra garanzia, infine, il materiale che venga smontato, riparato o comunque manomesso da altri che non siano stati da noi espressamente autorizzati a farlo. Noi decliniamo ogni responsabilità per i danni materiali e corporali che possano essere causati dai nostri attuatori. Il materiale difettoso dovrà essere restituito alla nostra officina in porto franco e una volta da noi riconosciuto che il difetto ricade sotto la nostra responsabilità, sarà restituito in porto assegnato.

**PROVE.** Le prove vengono eseguite presso le nostre officine anche in presenza del Cliente qualora ciò sia richiesto.

**FORO COMPETENTE.** Per la risoluzione di ogni controversia il foro competente è solo quello di Brescia, anche se il pagamento è avvenuto a mezzo tratta.

**LA DITTA SI RISERVA LA FACOLTA' DI APPORTARE MODIFICHE AI PRODOTTI SENZA DOVER DARE PREAVVISO AL CLIENTE.**

**GENERAL SALES CONDITIONS**

**PURCHASE ORDERS.** All orders passed to our agents shall be confirmed by our Sales Management .

**PRICES.** Prices do not include tax charges . Following to general increases in production costs or for any other reason, prices may be modified without previous notice. Prices in the price list refer to normal current production.

**DELIVERY.** Delays in delivery due to acts of God or to any other reason do not justify order cancellation and no indemnity shall be due for such delays. We consider partial shipments as authorized. Eventual packaging on customer's charge.

**FORWARDING.** Goods are forwarded at the risk of the purchaser. In case of dispute, the purchaser shall immediately report to the forwarding agent by registered letter, and a copy of the letter shall be sent to our company.

**PAYMENTS.** Our invoices can be paid by cash or according to the terms agreed and accepted at the moment of the order. For orders of special products, payment shall be:  
- one/third of the total amount at the moment of the order.  
- balance payment at 30 days date of the shipment, end of month.

**PROPERTY OF THE PRODUCTS.** All delivered products shall remain of our property till the full amount of the corresponding invoice has been paid. In case of any unjustified payment delay, our company shall be entitled to claim the immediate return of all delivered goods (carriage free).

**GUARANTEE.** The general guarantee is valid for 6 months, starting from the date of shipment. Such guarantee covers any and all manufacturing defects of the materials produced by our company. Our guarantee provides for repairing or replacement of the actuator or the defective pieces; repairing shall be made by us at our factory. In no cases, does this guarantee give the purchaser the right to claim indemnity. This guarantee does not cover failures produced by wrong connections, lack or appropriate protection, improper assembly, mis-manoeuvres and, general, careless plant execution. The guarantee is not valid in the following cases: - malfunctions caused by improper installation; - default in payments; - this guarantee does not include all those products that have been disassembled, repaired or somehow tampered with by operators who have not been specifically authorized by our company. Our company herewith declines all responsibility for any and all material damages or casualties that may be caused by our actuators. The defective product shall be returned to our company (carriage free) and after acknowledgement that the failure was due to the manufacturer's responsibility, it shall be send back to the purchaser (carriage forward).

**TESTING.** Testing is carried out at our factory, in the Purchaser's presence, if requested.

**COMPETENT COURT.** Should any dispute arise, the only competent court is the one of Brescia, also in case of payment by draft.

**THE COMPANY RESERVES THE RIGHT TO MAKE PRODUCT CHANGES WITHOUT PREVIOUS NOTICE TO THE PURCHASER.**



Progettazione CAD, CAD design  
CAD projekt, Projet CAD

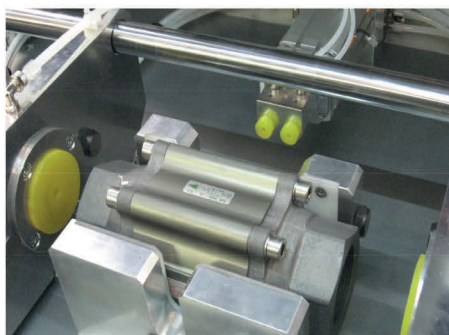

Test ad alta pressione/vuoto, High pressure/vacuum test  
Hoch/leer druckprüfung, Essais à haute pression/vide



Shock termico, Thermal shock  
Thermoschock, Choc thermique

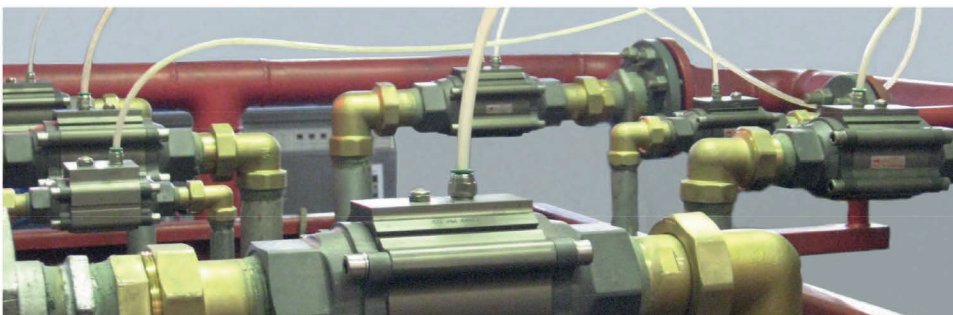

Test di durata in esercizio, Long life test in operation  
Langzeit funktionstest, Essai d'endurance en travail



Test in nebbia salina, Salty fog test  
Salznebel test, Essai en atmosphère saline





Tutti i diritti riservati - Non garantito per accuratezza - Dati soggetti a modifiche senza preavviso - Versioni precedenti non più valide  
All rights reserved - Not guaranteed for accuracy - Data subject to change without notice - Older data sheets are invalid  
Alle Rechte vorbehalten - Nicht für Genauigkeit garantiert - Der Katalog kann jederzeit ohne vorherige Ankündigung geändert werden - Ältere Datenblätter sind ungültig  
Tous les droits sont réservés - Il n'est pas garanti la précision - Données sujet à changement sans préavis - Fiches techniques âgées sont invalides  
Rev. 30/09/2016